



## Vivaspin 15R

Technical data and operating instructions.  
For in vitro use only.

**New**  
2 kDa MWCO  
Hydrosart  
in Vivaspin 15R

# Vivascience Vivaspin 15R

## Storage conditions / shelf life

Vivaspin ultrafiltration spin columns should be stored at room temperature.

The devices should be used before the expiry date printed on the box.

## Introduction

Vivaspin concentrators are disposable ultrafiltration devices for the concentration and/or purification of biological samples. Vivaspin 15R is suitable for sample volumes of 3- 15 ml.

The innovative design (US Patent No. 5,647,990, second patent pending), ease of use, speed and exceptional concentrate recoveries are the main features of the concentrators.

## Centrifugal Operation

Vivaspin concentrators can be used in swing bucket or fixed angle rotors accepting standard conical bottom tubes. In a single spin, solutions can be concentrated in excess of 100 X. Samples are typically concentrated in 10 to 30 minutes with macromolecular recoveries in excess of 95 %. The longitudinal membrane orientation and thin channel concentration chamber, provide optimum cross flow conditions even for particle laden solutions; the centrifugal force pulling particles and solids away from the membrane to the bottom of the device. Macromolecules collect in an impermeable concentrate pocket integrally moulded below the membrane surface, thereby eliminating the risk of filtration to dryness.



## Equipment Required

1. Centrifuge with swing bucket or fixed angle rotor (minimum 25°).
2. Pasteur or fixed volume pipettes for sample delivery and removal.

Device	Carrier Required
Vivaspin 15R	50 ml / 30 mm Ø

Equipment required	Vivaspin 15R
Centrifuge	
Rotor type	Swing bucket or Fixed angle
Minimum rotor angle	25°
Rotor cavity	To fit 50 ml (30 mm) conical bottom tubes
Concentrate recovery	
Pipette type	Fixed or variable volume
Recommended tip	Thin gel loader type

## Rotor compatibility

**Please note:** Vivaspin 15R (30 mm x 116 mm) is designed to fit into rotors that can accommodate Falcon 50 ml conical bottom tubes, e.g. Beckman Allegra 25R with TS-5.1-500 swing-out rotor with BUC 5 buckets and 368327 adaptors; Beckman TA-10.250 25° fixed angle rotor with 356966 adaptors; Heraeus Multifuge 3 S-R with (Heraeus / Sorvall) 75006445 swing out rotor with 75006441 buckets and adaptors for Falcon 50 ml conical bottom tubes.

These devices are not designed to fit into rotors that only accept round bottom 29 mm x 105 mm tubes, e.g. Sorvall SS34 Beckmann JA 20. If your rotor accepts only 29 mm x 105 mm round bottom tubes, please use the Vivaspin 15, which can be used in either round bottom or conical centrifuge tubes.

### Operation

1. Select the most appropriate membrane cut-off for your sample.  
For maximum recovery select a MWCO at least 50 % smaller than the molecular size of the species of interest.
2. Fill concentrator with up to the maximum volumes shown in table 1.  
(Ensure screw closure is fully seated)
3. Insert assembled concentrator into centrifuge (when fixed angle rotors are used, angle concentrator so that the top and window faces upwards/outwards).
4. Centrifuge at speeds recommended in table 2, taking care not to exceed the maximum g force indicated by membrane type and MWCO
5. Once the desired concentration is achieved, (see table 3 for guide to concentration times), remove assembly and recover sample from the bottom of the concentrate pocket with a pipette.

### Desalting/Buffer Exchange

1. Concentrate sample to desired level.
2. Empty filtrate container.
3. Refill concentrator with an appropriate solvent.
4. Concentrate the sample again and repeat the process until the concentration of contaminating microsolute is sufficiently reduced. Typically, 3 wash cycles will remove 99 % of initial salt content.

Table 1: Technical specifications	Vivaspin 15R
Concentrator capacity	
Swing bucket rotor	15 ml
Fixed angle rotor	12.5 ml
Dimensions	
Total length	116 mm
Width	30 mm
Active membrane area	3.9 cm <sup>2</sup>
Hold up volume membrane	< 20 µl
Dead stop volume	30 µl
Materials of construction	
Body	Polycarbonate
Filtrate vessel	Polypropylene
Concentrator cap	Polycarbonate
Membrane	Hydrosart

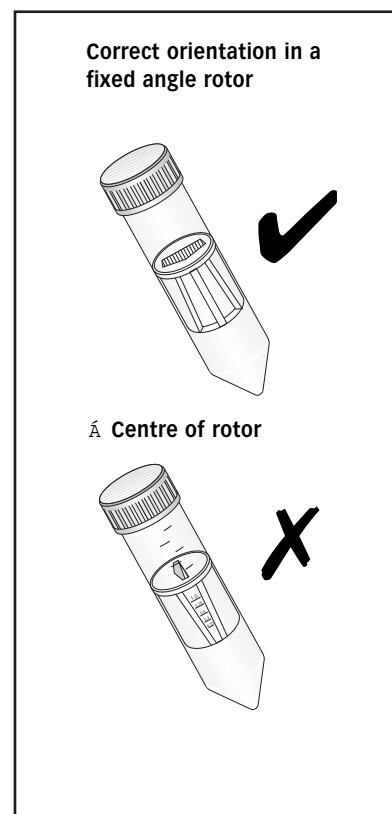
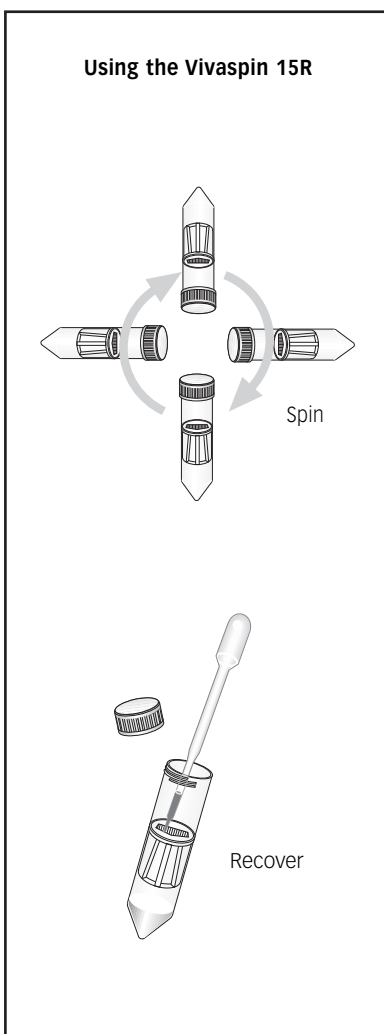

## Usage Tips

### 1. Flow Rate

Filtration rate is affected by several parameters, including MWCO, porosity, sample concentration, viscosity, centrifugal force and temperature. Expect significantly longer spin times for starting solutions with over 5 % solids. When operating at 4° C, flow rates are approximately 1.5 times slower than at 25° C. Viscous solutions such as 50 % glycerine will take up to 5 times longer to concentrate than samples in a predominantly buffer solution.

### 2. Prerinsing

Membranes fitted to Vivaspin concentrators contain trace amounts of Glycerine and Sodium azide. Should these interfere with analysis they can be removed by rinsing fill volume of buffer solution or deionised water through the concentrator. Decant filtrate and concentrate before processing sample solution.

### 3. Sterilisation

To sterilise, use a 70 % ethanol solution or sterilising gas mixture.

### 4. Chemical Compatibility

Vivaspin concentrators are designed for use with biological fluids and aqueous solutions. For chemical compatibility details, refer to table 4.

**Table 2: Recommended Spin Speed (xg)**

Vivaspin15R		
Membrane	Swing Bucket	Fixed Angle
2 - 30,000 MWCO Hydrosart	6,000	3,000

**Table 3: Typical performance**

	Time to concentrate 30x min. at 20°C and solute recovery %			
	Swing bucket		25° Fixed angle	
Start volume	15 ml		12.5 ml	
	Min.	Rec.	Min.	Rec.
<b>Insulin chain A 0.1 mg/ml* (2,500 MW)</b>				
2,000 MWCO	70	96 %	60	96 %
<b>Aprotinin 0.1 mg/ml* (6,500 MW)</b>				
5,000 MWCO	47	95 %	45	95 %
<b>Cytochrome c 0.25 mg/ml* (12,400 MW)</b>				
5,000 MWCO	45	96 %	45	96 %
10,000 MWCO	25	94 %	18	94 %
<b>α-chymotrypsin 0.25 mg/ml* (25,000 MW)</b>				
5,000 MWCO	50	98 %	45	98 %
10,000 MWCO	25	98 %	18	98 %
<b>Ovalbumin 1.0 mg/ml* (45,000 MW)</b>				
10,000 MWCO	20	98 %	14	98 %
30,000 MWCO	15	94 %	12	94 %
<b>BSA 1.0 mg/ml* (66,000 MW)</b>				
30,000 MWCO	18	98 %	15	98 %
<b>IgG 0.1 mg/ml*in DMEM (160,000 MW)</b>				
30,000 MWCO	30	98 %	25	96 %

\* proteins other than IgG made up in 50 mM potassium sulphate, 150 mM sodium chloride, pH 7.4

**Ordering information**

Vivaspin 15R Hydrosart	Pack size	Prod. no.
2,000 MWCO	12	VS15RH91
2,000 MWCO	48	VS15RH92
5,000 MWCO	12	VS15RH11
5,000 MWCO	48	VS15RH12
10,000 MWCO	12	VS15RH01
10,000 MWCO	48	VS15RH02
30,000 MWCO	12	VS15RH21
30,000 MWCO	48	VS15RH22

**Table 4: Chemical Compatibility (2hr contact time)**

Solutions - Compatible pH range pH 1-9		Solutions - Compatible pH range pH 1-9	
Acetic Acid (25.0 %)	OK	Lactic Acid (5.0 %)	OK
Acetone (10.0 %)	NO	Mercaptoethanol (10 mM)	OK
Acetonitrile (10.0 %)	NO	Methanol (60 %)	OK
Ammonium Hydroxide (5.0 %)	OK	Nitric Acid (10.0 %)	NO
Ammonium Sulphate (saturated)	?	Phenol (1.0 %)	NO
Benzene (100 %)	NO	Phosphate Buffer (1.0 M)	OK
n - Butanol (70 %)	?	Polyethylene Glycol (10 %)	?
Chloroform (1.0 %)	NO	Pyridine (100 %)	NO
Dimethyl Formamide (10.0 %)	NO	Sodium Carbonate (20 %)	?
Dimethyl Sulfoxide (5.0 %)	NO	Sodium Deoxycholate (5.0 %)	?
Ethanol (70.0 %)	OK	Sodium Dodecylsulfate (0.1 M)	OK
Ethyl Acetate (100 %)	NO	Sodium Hydroxide (2.5 M)	NO
Formaldehyde (30 %)	OK	Sodium Hypochlorite (200 ppm)	NO
Formic Acid (5.0 %)	OK	Sodium Nitrate (1.0 %)	OK
Glycerine (70 %)	OK	Sulfamic Acid (5.0 %)	?
Guanidine HCl (6 M)	OK	Tetrahydrofuran (5.0 %)	NO
Hydrocarbons, aromatic	NO	Toluene (1.0 %)	NO
Hydrocarbons, chlorinated	NO	Trifluoroacetic Acid (10 %)	OK
Hydrochloric Acid (1 M)	OK	Tween 20 (0.1 %)	OK
Imidazole (500 mM)	?	Triton X-100 (0.1 %)	OK
Isopropanol (70 %)	OK	Urea (8 M)	OK

OK = Acceptable ? = Questionable NO = Not recommended

## Vivascience ultrafiltration product range at a glance

Product	Sample volume	Mode	Membranes available
Vivaspin 500	100 µl - 600 µl	Centrifugal	Polyethersulfone
Vivaspin 2	0.4 ml - 2 ml	Centrifugal	Polyethersulfone, Cellulose Triacetate Regenerated Cellulose, Hydrosart®
Centrisart	0.5 ml - 2.5 ml	Centrifugal	Polyethersulfone, Cellulose Triacetate
Vivaspin 4	1 ml - 4 ml	Centrifugal	Polyethersulfone
Vivaspin 6	2 ml - 6 ml	Centrifugal	Polyethersulfone
Vivaspin 15	2 ml - 15 ml	Centrifugal	Polyethersulfone
Vivaspin 15R	2 ml - 15 ml	Centrifugal	Hydrosart®
Vivaspin 20	5 ml - 20 ml	Centrifugal Gas pressure	Polyethersulfone
Vivacell 70	10 ml - 70 ml	Centrifugal Gas pressure	Polyethersulfone
Vivacell 100	20 ml - 100 ml	Centrifugal Gas pressure	Polyethersulfone
Vivacell 250	50 ml - 250 ml	Gas pressure	Polyethersulfone
Vivaflow 50	100 ml - > 5 l	Tangential flow	Polyethersulfone, Regenerated Cellulose
Vivaflow 200	500 ml - > 5 l	Tangential flow	Polyethersulfone, Regenerated Cellulose, Hydrosart®
Vivapore 2	0.5 ml - 2.5 ml/15 ml	Solvent absorption	Polyethersulfone, Regenerated Cellulose
Vivapore 5	1 ml - 5 ml	Solvent absorption	Polyethersulfone, Regenerated Cellulose
Vivapore 10/20	2 ml - 10 ml/20 ml	Solvent absorption	Polyethersulfone, Regenerated Cellulose
Vivapore Q5	0.5 ml - 5 ml	Solvent absorption	Polyethersulfone
Vivapore Q10	1 ml - 10 ml	Solvent absorption	Polyethersulfone



### New Vivapure kits and devices now available

The development of the innovative Vivapure range continues with the launch of new protein purification kits and devices. Vivapure spin columns are currently available with metal chelate protein A, epoxy and ion exchange membrane chemistries.

Contact us for more details or visit [www.vivascience.com](http://www.vivascience.com)

Vivascience Technical Support		Phone	Fax	E-mail
USA	Vivascience Service & Technical Support	+1 877 452 2345 (toll free)	+1 631 253 5460	info.usa@vivascience.com
Europe	Vivascience Support Center	+49 1 802 848 201 (toll free)	+49 1 802 848 202	info@vivascience.com
International	Vivascience Support Center	+49 511 524 875 60	+49 511 524 875 69	info@vivascience.com
Vivascience Customer Sales				
France	Vivascience S.A.R.L.	+33 169 19 93 23	+33 160 13 95 05	info.france@vivascience.com
Germany	Vivascience AG	+49 551 308 4023	+49 551 308 3289	info.germany@vivascience.com
UK	Vivascience Ltd.	+44 1372 737 159	+44 1372 726 171	info.uk@vivascience.com
USA	Vivascience Inc.	+1 877 452 2345	+1 631 253 5445	info.usa@vivascience.com

### Vivascience AG

Feodor-Lynen-Strasse 21      Phone: +49 511 524875-0      E-mail: [info@vivascience.com](mailto:info@vivascience.com)  
 30625 Hannover, Germany      Fax: +49 511 524875-19      Web: [www.vivascience.com](http://www.vivascience.com)